

## *Path Align-R™* FIELD VERIFICATION CHECK.

**CAUTION.** When connecting the SMA terminated end of the cable to the front panel Band connector, do not overtighten the SMA cable connector as it can damage the front panel connector's center pin. A 5/16" open-end wrench fits SMA connectors; recommended torque is 8-inch/pounds. A special 5/16" open end torque wrench with an 8-inch/pound setting is available from Torque Controls, So. El Monte, California. The manufacturer part number is 'A5'.

The following operational checks of the *Path Align-R™* may be made by personnel in the field to confirm proper operation of both *Path Align-R™* units, their coax cables and the waveguide adapters (transitions). This confirmation may be made prior to climbing the towers or whenever an operational confidence check needs to be made in the field, without access to test equipment or electronic technicians. The Band 1 (1.8–2.5 GHz) check is given first, using a 40 dB attenuator. Bands 2, 3, and 4 are given next, using the appropriate waveguide adapters. Figures 1 (Band 1) and 2 (Bands 2, 3 & 4) illustrate the setups.

### **Band 1 (1.8–2.5 GHz) Field Verification Check (see Figure 1, page 2).**

1. First, using two SMA terminated coax cables, connect one end to the Band 1 connector on each *Path Align-R™*. Connect the other end of each cable to a 40 dB in line attenuator.  
*Note: Without the attenuator, the input circuits of the Path Align-R™ would overload. The attenuator needs to pass frequencies from DC through 18 GHz. An appropriate attenuator is manufactured by Mini-Circuits, Brooklyn, NY, model BW-S40W2, and sells for about US\$30.*
2. Using the thumbwheel switches, select any Band 1 frequency.  
*Note: The Path Align-R™s thumbwheels must be set to the same frequency on both units.*
3. Set one *Path Align-R™* to 'MASTER' and the other *Path Align-R™* to 'SLAVE' and then power up both units.
4. Observe that the LED over the Band 1 connector on each unit is lit, indicating operation of that band.
5. The path loss indicated on the meter should be close to 40 dB. If the loss is significantly different, check or replace the coax cables or attenuator and repeat the above test.  
*Note: The two 2200s should typically read within 4 dB of one another.*
6. This completes the field operational confidence check of Band 1.

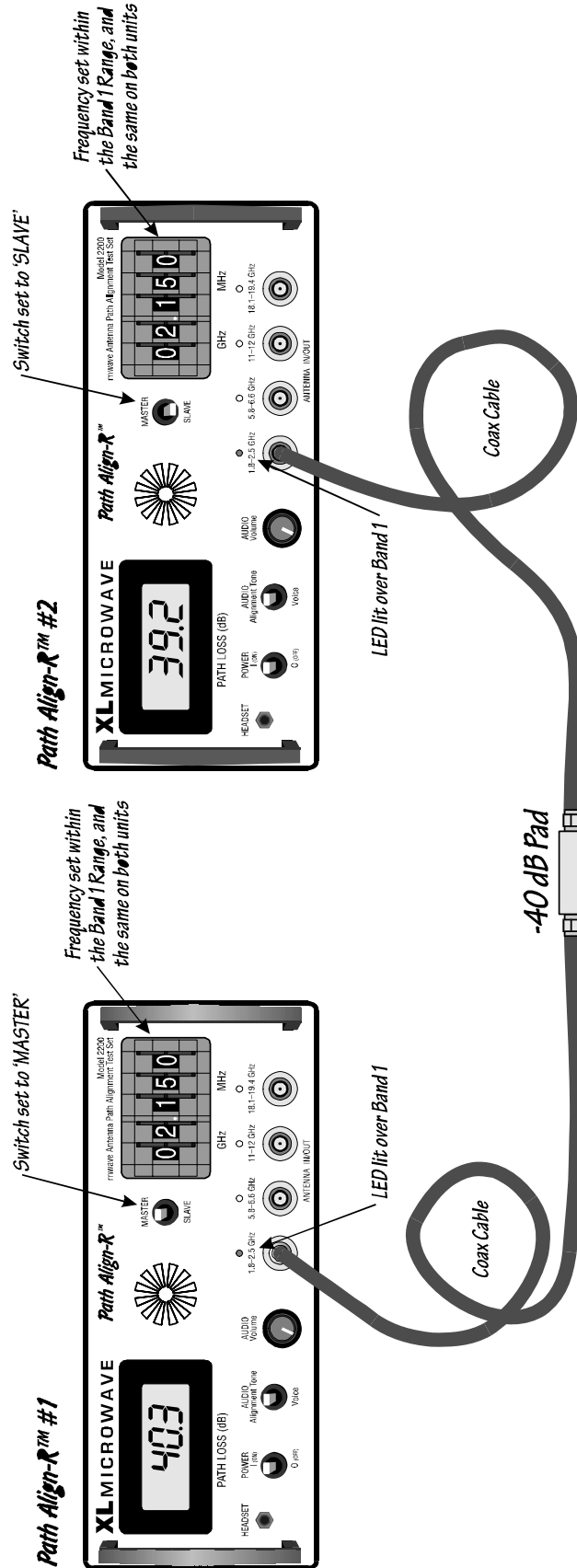
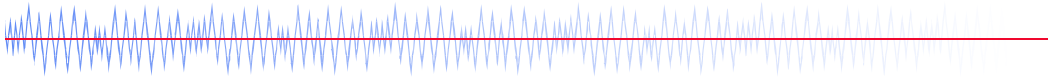

Figure 1. Band 1 Field Verification Check Test Setup.



## Band 2, Band 3, and Band 4 Field Verification Check (see Figure 2, page 4).

1. First, connect the coax cable to the proper Band connector on each *Path Align-R™* and then, connect the waveguide adapter (transition) to the other end of this coax making sure that the waveguide adapter band is appropriate for the *Path Align-R™*'s frequency band range.

*Note: It is absolutely necessary for the proper waveguide to be used. Waveguides are designed to work within a limited frequency range and a waveguide's cutoff frequency WILL NOT allow frequencies to propagate below this cutoff frequency! Frequencies above the waveguide's passband will encounter multi-mode effects and their throughput will be unpredictable.*

2. Using the thumbwheel switches, select the appropriate Band frequency on both *Path Align-R™*'s (thumbwheels must be set to the same frequency on both units).

3. Set one *Path Align-R™* to 'MASTER' and the other *Path Align-R™* to 'SLAVE' and then power up both units.

4. Observe that the LED over the appropriate band connector on each unit is lit, indicating operation of that band.

5. Face the opening of each waveguide adapter towards the other, with approximately a 3-foot space between them.

6. If both *Path Align-R™*'s, coax cables, and waveguide adapters are operating correctly you should observe the following path loss (displayed on each *Path Align-R™*'s meter):

For Band 2 (5.8–6.6 GHz) & a WR-137 waveguide adapter: approx. -40 dB;

For Band 3 (11–12 GHz) & a WR-90 waveguide adapter: approx. -50 dB; and,

For Band 4 (18.1–19.4 GHz) & a WR-42 waveguide adapter: approx. -60 dB.

*Note: The two 2200s should typically read within 4 dB of one another.*

7. The path loss you observe should be close to the above numbers. If the loss is significantly different, check or replace the coax cables or waveguide adapters and repeat the above test.

8. This completes the field operational confidence check.

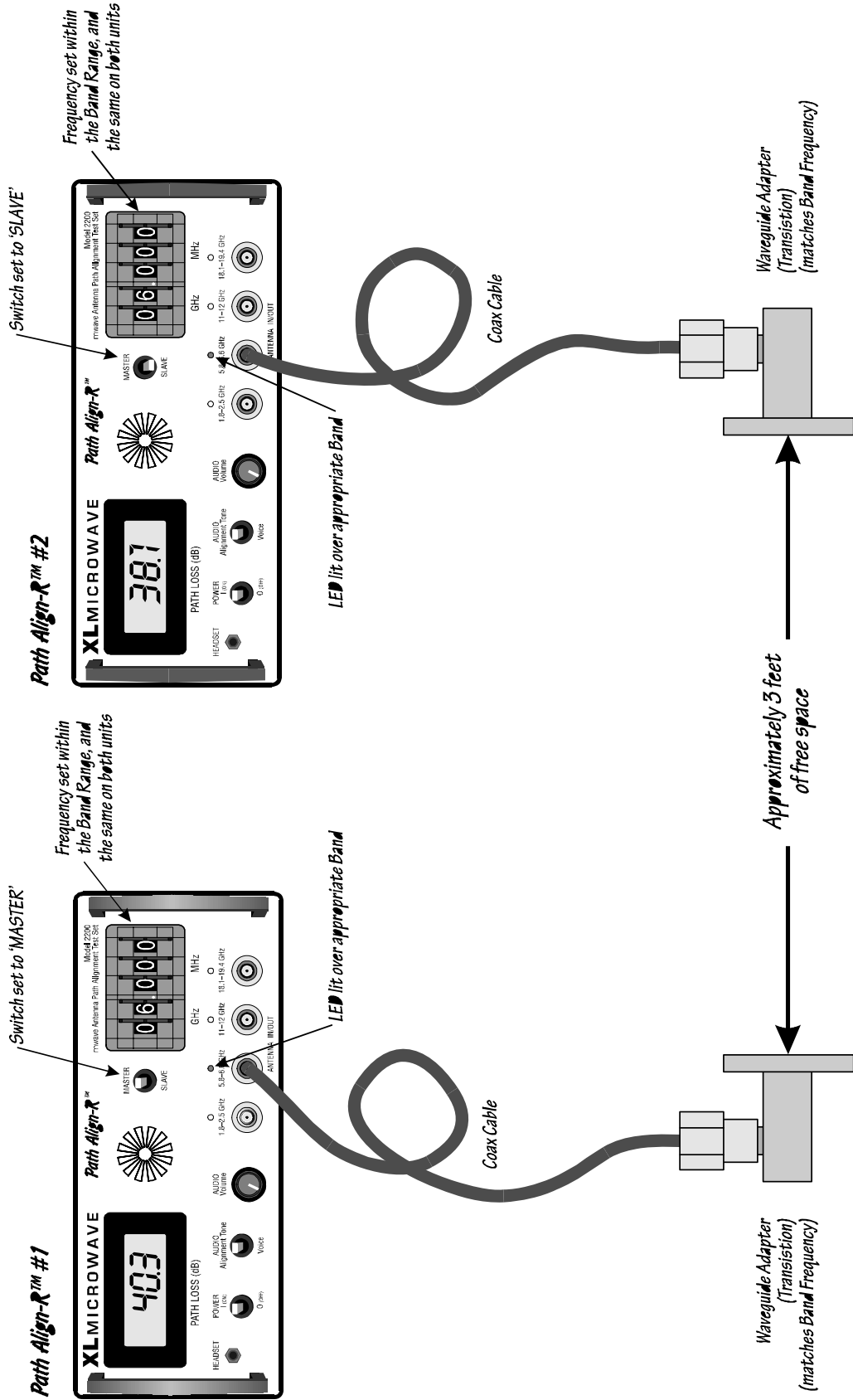

Figure 2. Bands 2, 3, & 4 Field Verification Check Test Setup.